

## Composition of the MBV 2001 H Vice (see Fig.1) :

1. Base with a fixed jaw
2. Sliding jaw
3. Spindle
4. Setting ring
5. Hydraulic unit

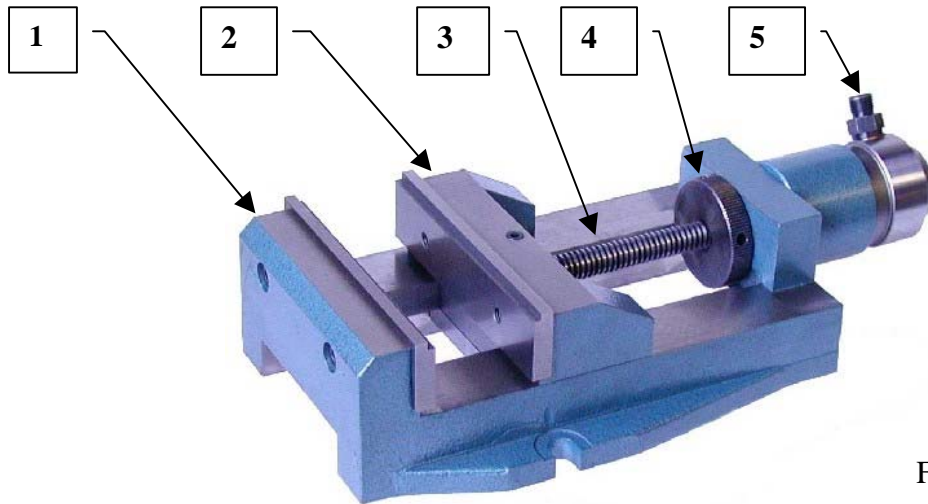

Fig. 1

## 1. General

The vice is fastened to the working board using M12. This vice enables you to clamp objects in classical mechanical way or using the Hydraulic unit (5). The shifting to the clamped object is performed always mechanically. When clamping hydraulically, the play between the jaw and the object is allowed to be 4 mm max. before using the hydraulic-tyred roller.

## 2. Mechanical clamping

By turning the Setting ring (4) clockwise, clamp the clamped object mechanically. By turning the cylindrical body vice versa, unclamp it. To reach a bigger clamping power, use the openings in the ring to insert an auxiliary lever.

## 3. Hydraulic clamping

The hydraulic stroke from the locked position is 4mm. The hydraulic piston clamps under pressure. When the piston is released, return springs provide automatic unclamping of the clamped object. The size of the clamping power can be set according to the working liquid pressure gauge. **ATTENTION!!** Max. liquid working pressure .... 20 MPa.

## 4. *Warning!!*

Before the first starting, open the vice to 80 mm at least, turn on the air intake and verify the functionality. Before clamping using the Hydraulic unit (5), only the clamped object is allowed to be in the clamped space. There is a risk of injury in case of careless handling (e.g. crushing of fingers!!).